

# Design Drafting NEWS<sup>TM</sup>

## Ron McDonald ADDA President



### Random Thoughts on Retirement

This September, I will retire after 45 years in the drafting/design profession. During those 45 years, I have seen and experienced many changes in the profession, some good and in my opinion not so good. I have had the opportunity to work in the aerospace, transportation and pipeline equipment industries. All have added to my professional knowledge and have given me the opportunity to experience design of different products, from military aircraft to over the road tankers and then finally pipeline equipment. However, I regret that I have had no real exposure to the other areas of the profession such as civil, architectural, structural and electrical, etc. More on that thought later in the message.

The profession changed over the years. From rooms full of drafters, drafting table/ machines, sounds of the blueprint machine, the smell of eraser dust, the sound of electric erasers, trying to master the 'Leroy' lettering set, writing pages of notes by hand and then having to erase what you did yesterday because the requirements have changed. Then with the arrival of Computer Aided Design (CAD), the drafter/designer was promised that productivity would improve and it did. That new tool also offered new challenges such as plotter pens running dry halfway through a plot, printer paper jams and the inevitable crash. For the most part, CAD has enabled the drafter/designer to produce quite accurate drawings that can be easily edited or modified in a shorter time frame. However, I have noticed another issue since the arrival of CAD.

That is the drafter/designer relies too much on the software and has in my opinion either forgotten or never really learned basic

Continued on Page 6

## On the Drawing Board

2013 ADDA Conference—Kansas City  
On-Line Examination & Review Guide Updates  
New Website & Development - Sept 2012  
Museum Donations and Funding Grants  
New Examination Development and Grants

## As Built

Random Thoughts	Page 1,6
ADDA Certification brings success	Page 2
Professionalism	Page 3
Drafting Contest	Page 4,9
Ethics Thought	Page 6
Poster Contest	Page 7
Call for White Papers	Page 7
Skills Moving	Page 10
Membership Levels	Page 10
Curriculum Certification	Page 10
Difference Between Counterbore	Page 11
Meet in Kansas City	Page 12

A graphic advertisement for the 54th Annual Conference. It features the letters 'KC' in a large, bold, yellow-to-orange gradient font with a black outline. Below this, the text '54th Annual Conference' is written in a smaller, bold, yellow-to-orange gradient font. Underneath that, 'April 09 - 12, 2013' is written in the same style. At the bottom, 'Kansas City Missouri' is written in a similar style. The entire graphic is set against a dark, rounded rectangular background with a white border.

## ADDA Certification brings Success E. H. Lindsey

Jack Welch said "If you don't have a competitive advantage, don't compete.

I wish to share with ADDA three success stories that I have had here at Citrus High School in Central Florida through the last several years.

A former student, upon graduating from Citrus High School in 2008, obtained employment in the construction industry. After two years of freezing winters and blistering summers, he started on his associate's degree at night. Before he had completed his degree, he had an opportunity to apply for a drafting position at a local electrical power generating facility. During the interview, he was asked if he had any certifications. He produced his ADDA Professional Mechanical Drafting Certification card. And according to the story my former student told me, the interview was over and he was being introduced to his new co-workers. This former student has since come to me asking for help and guidance in purchasing his first house. His appreciation for his drafting education and ADDA Certification, in his words, 'changed my life.'

Another young man, graduated from Citrus High School, who obtained his Professional Mechanical Drafting Certification in 2008. During his college career he obtained three summer internships. This young man admitted to me that he obtained that internship solely because of his ADDA Drafting Certification. Upon graduating from college, with his certification and three internships, he received five different job offers with salaries ranging from \$65,000.00 to \$95,000.00. In his letter to me, he commented that his only decision was 'Where he wanted to live.'

And not my last This success story also comes from a young lady, also the class of 2008. She sent me a letter from school informing me that she will be graduating in December of 2012, has had four internships and has landed a very lucrative job in Massachusetts and has been accepted to MIT's Electrical Engineering Master's Degree Program. I remember the first day she came into my class, intimidated by the drawings on the wall. She mastered them and obtained her Mechanical Certification here. She has freely admitted that her certification gave her the confidence to tackle and achieve her college degree.

These are but a few, very few of my success here at Citrus High School. I have over 48 young men and women serving in our nation's military services in technical capacities. All these former students tell me the same thing, their first step in realizing their full potential and successes was obtaining their ADDA Mechanical Drafting Certification.

There is more than just my student success stories. My involvement with the ADDA has made me a much better and more focused Drafting Instructor. It has given me the framework and the professional credentials my students, parents, administration and community recognizes a qualified program should have. The reputation of the Drafting Program here at Citrus High School has spread to other surrounding counties and I receive calls from other Drafting Instructors wanting to duplicate the success we have obtained.

On two separate occasions, two different companies, have posed the following questions to their prospective employee. "Do you hold your Drafting Certification from the ADDA?" and "Did you graduate from the Drafting Program at Citrus High School?" Another example comes from a nearby nuclear power generating facility, their hiring supervisor for engineering interns, simply stated "We will not interview an applicant unless they hold their ADDA Drafting Certification". In my experience, that explains it all.



Atlanta Georgia  
Nov. 29—Dec. 01, 2012



## Professionalism Building the Proper Foundation



What do we mean when we talk about Professionalism? More importantly, what do we mean by "Building a Proper Foundation"? Consider the building of a house. What is the first thing that is done before the actual erection of the house, or building? A foundation is laid. Why? Without a foundation, the rest of the building will not be sturdy and the first wind or earthquake would destroy it. In your line of work, you also have to lay a foundation in order to be perceived as having professionalism.

How is Professionalism defined? You can go to any dictionary and get a very concise definition. Merriam-Webster states the following: "the conduct, aims, or qualities that characterize or mark a profession or a professional person." So, we have conduct, aims, or qualities as those things that mark professionalism.

Another definition that fits more appropriately to our discussion might be: "meticulous adherence to undeviating courtesy, honesty, and responsibility in one's dealings with customers and associates, plus a level of excellence that goes over and above the commercial considerations and legal requirements."

Let's break down some of these points that have been presented and see if we can begin to lay a good foundation.

**Conduct:** How do you conduct yourself around your fellow workers or supervisors? Do you treat them with respect? Do you honestly listen to their views and give those views your full attention by taking and possibly using their suggestions or allow their opinions to be considered? Are you reliable; at work on time, stay until the stated work day ends and give 100 percent of your time to the company? When given a deadline, do you deliver on time? As you can see, conduct plays a very critical role in laying a foundation of professionalism.

**Aims:** What are your goals; your aim in working? Is it to better the company or to get the most for you? Here we have another part of the foundation. When your company sees that your goals; your aim for working is for the company's benefit, you become more professional in their eyes.

**Qualities:** This might be a more vague part of the foundation but here we can look at our self. Might qualities be how we are dressed when we come to work? It is common today for most companies to not require ties in the office, though do not be deceived, there are still those companies around. But, even without a required tie, how should we present ourselves? I have found that if the company work attire rules state business casual, that usually means Dockers, shoes of some sort that can take a polish, and either a short sleeve or long sleeve Oxford shirt. Many companies include polo shirts in this classification as well as clean and neat jeans. But wait, you want to be considered a professional and show professionalism. It is here that you can shine. Even if jeans are allowed, if you were to come to work everyday wearing slacks, a nice Oxford shirt and casual loafers; while others wore jeans and not so good looking shirts; who do you think the management would look at as being more professional? You got it...you! Here is a third, and maybe, final section of the foundation. Qualities will also include those shown in the second definition.

Now, if we put all these items together, into the foundation of our professional actions, would we not appear as someone that not only knows what we are doing but also has a confident air about them? It is these things that start the foundation of our having professionalism and being considered professional. I can almost say without a doubt that those that practice these foundational actions will not only succeed in their work but will advance much faster than those that don't.

I hope you found this short article of some interest and you may see a more detailed article in the future. Thank you for reading and remember, a professional always portrays the proper ethics, actions, appearance, and communications.

**GET INVOLVED with ADDA**  
Your Membership or Certification should be more than a  
CARD  
Start a Professional Council—Be a Contest Judge

"To give real service you must add something which cannot be bought or measured with money, and that is sincerity and integrity.

*Douglas Adams*

## Annual Drafting Contest Tony Whitus

In 1967 the ADDA Board of Directors introduced the annual Drafting Contest as a means of recognizing outstanding training programs, to encourage excellence in effort and discipline, and to give recognition to outstanding students and design/drafting programs. During the early years, the instructors hand-carried the student entries to the conference where they were evaluated and winning entries identified. Each year the program has evolved and the 2013 contest will mark the 46<sup>th</sup> consecutive year.

**ELIGIBILITY:** To enter the contest students must be either:

- A current member of an ADDA Student Chapter.
- Currently enrolled in a school with curriculum certified by the Association.
- Currently enrolled in a school having an Educational Institution Membership.

**ORGANIZATION** The contest is divided into two categories, Advanced and Beginning.

**Category A** is for advanced students. An advanced student is one that by the contest close date has completed 3 or more full semesters of classroom training in drafting with at least 1 semester, or 2 quarters, at the post-secondary level. For instance, a student in their 2nd year of technical school or college or a student in their 1st year of technical school or college with 2 semesters of drafting in High School would be classed as an advanced student. You will notice that this category will contain both CAD and manually prepared entries.

**Division A is for advanced students as described above.**

- |   |  |
|---|--|
| A-RES Architectural Residential Design Drafting | A-COM Architectural Commercial Design Drafting |
| A-APRE Architectural Rendering                  | A-MECH Machine and Mechanical Working Drawings |
| A-TILM Technical Illustration, Mechanical       | A-OPEN Open                                    |

**Category B** is for beginning students. A beginning student is one that by the contest close date is a High School student or has completed less than 2 full semesters or 3 quarters of post-secondary training in drafting. This category will also contain both CAD and manually prepared entries.

**Division B is for beginning students as described above.**

- |  |  |
|--|--|
| B-ARES Architectural Residential Design Drafting | B-COM Architectural Commercial Design Drafting |
| B-APRE Architectural Rendering                   | B-MECH Machine and Mechanical Working Drawings |
| B-TILM Technical Illustration, Mechanical        | B-OPEN Open                                    |

**JUDGING CRITERIA** The Judges look for good drafting techniques and skills. Judging is based on the principles and theories of the profession and not based on the creation process. Entries are evaluated according to the 'letter of the rules.' and based on both industry standards and ANSI/ASME Standards on the following:

### Judging Criteria

- |  |   |  |
|--|---|--|
| Appearance/Neatness                      | Accuracy  | Creativity                             |
| Line work, Line Type differentiation     | View Selection  | Reproducibility and legibility of plot |
| Organization (correct view placement)    | Dimensioning, dimensioning styles                                 | Spelling                               |
| Lettering, font size and appropriateness | Title Block (correct, unmodified use of the ADDA Contest Formats) |  |

Continued on page 9

54th Annual Technical Conference  
 KANSAS CITY MISSOURI  
 April 09-12, 2013

Accommodations Provided by the



**Holiday Inn**  
 Country Club Plaza  
 One East 45th Street  
 Kansas City Missouri



**Teaching Systems, Inc.**  
**(800) 762-4133**  
**www.teachingsystems.com**

**For over 40 years**

*Teaching Systems, Inc. has been in the business of selling high end  
 audio visual, technical equipment, systems, software, services  
 technical support and leading laboratory solutions in*

*educational institutions in the states of Texas, Oklahoma and New Mexico.*

*If you would like to find out more about Teaching Systems, Inc. and their products you  
 can request literature at [www.teachingsystems.com](http://www.teachingsystems.com)*

1911 Bellvue West Drive, Suite 111  
 Arlington, Texas 76010



GRAPHISOFT.  
**ARCHICAD**

"The brain is a wonderful organ; it starts working the moment you get up in the morning and does not stop until you get into the office."

*Robert Frost*

**Chief Architect®**  
 3D Architectural Design Software



- Architectural Drafting
- Building & Construction
- Family & Consumer Science
- Interior Design & Housing

- Graphics & Theater Arts
- Ag & Horticulture
- Criminal Justice
- Applied Math
- Cabinetry



- Curriculum Provided
- 400+ Training Videos
- Step-by-Step Tutorials
- Certification Exams
- User-Friendly 3D Design for Students

No CAD Experience Needed!

- 2D & 3D Design
- Artistic & Photo Realistic Rendering
- Landscaping & Decks
- Kitchens & Baths
- Residential & Light Commercial
- CAD & Construction Drawings
- Materials List & Cost Estimating

[www.chiefarchitect.com](http://www.chiefarchitect.com)

1-800-482-4433

Continued from page 1-Random Thoughts-

drafting principles such as correct line weights, how to dimension and tolerance a part, view placement, understanding how the software just created that auxiliary or isometric view, what type of a section they just created, etc. I blame the computer age for this as most new drafting students or drafters want to use CAD instead of learning/mastering the profession's basic manual tools. I do understand. That shaded 3D model is much cooler to create than understand how such was created and then translate into a quality production/working drawing.

Now before you all grab your pitchforks and starting chanting get the tar and feathers, think of it this way: Would you have someone work on your car or perform needed surgery and the person doing task so did not have the basic fundamentals of what they were doing or why? I don't think so. We need to bring those basic fundamentals back through instruction and daily tasks on the job. Knowing CAD software is one thing but actually understanding what you are doing with it is another.

I mentioned earlier that my experience has mostly been in the mechanical area of the industry, without any actual exposure to other fields of the profession. While I did not receive any actual working exposure, I have been connected to a great organization that promotes and supports all of the professions fields, the ADDA.

This organization not only supports the professional but also the student, either in high school, junior college, technical school or college by offer training conferences, certifying a schools program and instructors and offering a proficiency test in different fields/skill levels. Plus I have had the pleasure to be exposed to drafting instructors and professionals in different fields than mine. Appreciation is not there until one understands how or why their requirements are vastly different that my experience has brought. Understanding civil drafting is still a mystery for me.

After my retirement, I will continue to serve on the ADDA's Board of Directors, as long as they will put up with me. My presidency of the Board will be always directed to the support of the profession and ADDA by looking for additional areas where we can make a difference.

I will now close with a trivia question. What is a 'drafting duck' and its purpose? If you want, you can send your answers to the ADDA's website email address for me.



## Ethics Thought

Dr. Christopher Bauer

### Might Your Company Need A Digestive Aid?

It is essential that everyone in your organization be fully aware of the values that your business espouses. It will be impossible for your employees to be adequately clear about those values, however, unless they can be stated in a manner that is clear, concise and easily 'digestible'. Said another way, if employees can't easily articulate, recall, and recite your values without thinking twice, you haven't yet refined them to the point at which they can be adequately easily digested, recalled, and used to their maximum benefit.

In creating or updating your values statement, be sure to write it in such a way that every employee will be able to easily and clearly determine whether or not their actions - each and every one of their actions, in fact - are aligned with your stated values.

Can it be difficult to state core values in a truly easily digestible style? Sure. However, it will be well worth the effort and time taken to do so. After all, unless your employees can fully understand and accurately remember each of your core values at all times, how can they be expected to persistently use them to judge whether or not their behavior is bringing those values to life throughout their working day?

Once created and appropriately implemented, a truly well-written values statement will pay off day after day through the increased focus and direction it will provide to everyone guided by it. In addition to his programs on professional ethics, Christopher Bauer helps companies build their bottom line through the development of values-driven management, leadership, customer service, and branding initiatives. Information on his programs can be found [here](#).

Interested in ethics commentary or resources? Both can be found at [Christopher Bauer's Ethics Nexus blog](#) and links to other ethics commentary and resources can be found on Twitter @ethicstweet. "Better Ethics NOW: How To Avoid The Ethics Disaster You Never Saw Coming (Second Edition)" is available for purchase [here](#). "A great book on ethics. Well done!" - Stephen M.R. Covey - Best-selling author of The Speed of Trust. copyright 2012 by Christopher Bauer - all rights reserved (Information on Bauer Ethics Seminars is available at [www.bauerethicsseminars.com](http://www.bauerethicsseminars.com).)

## Poster Contest

Each year in conjunction with the Annual Design Drafting Week, the ADDA sponsors a poster contest. One poster is chosen from the many entries and it is used to promote Design Drafting Week. The winning poster is chosen by the ADDA Board of Directors. In addition to being displayed in promotional material related to Design Drafting Week, the winning poster entrant receives a cash award of \$250.00. The 2012 poster contest winner was Kearra Clayton. Kearra is a student at Sullivan College of Technology and Design in Louisville, Kentucky. Her instructor is Diana Stewart. Her winning poster is shown below.



The annual poster contest is open to students enrolled in Graphic Design programs, Drafting Design programs, or other programs that would support the promotional process. Entries in the contest are subjected to strict rules relating to format and content. Each entry must display the ADDA logo, the "theme" for the year, and the dates of the Annual Design Drafting Week. Entries are received from all over the United States. Sometimes instructors in design programs use the contest as a project for the students and as many as 30 entries have been received from such programs. Other times there might be only one student in a program that participates. Either way, they all have a chance to win.

The poster contest is a great opportunity for students to show their creative skills and to get involved with the ADDA. Help make this years poster contest the best ever by entering. Visit [www.adda.org](http://www.adda.org) for an entry form and for complete information on the contest.

# Autodesk

## Call for White Papers 2013 ADDA Conference

ADDA is currently seeking speakers and presenters for the 2013 ADDA Technical Conference to be held in Kansas City Missouri, April 09-12, 2013.

Submissions may consist of any subject areas or projects related to the design drafting or graphic profession. Submission may be made by Companies, Suppliers, Students, Instructors or Manufacturers within the career field.

Papers will also be accepted for subjects such as ethics, professional development, standards and related areas for employment and employee development.

Submission should be received by 30, September 2012.

Email submissions to: [corporate@adda.org](mailto:corporate@adda.org)

Fax Submission to: 731-627-9321

Additional Information may be obtained on our website by visiting [www.adda.org](http://www.adda.org).



Changing the Way Companies  
**Develop Products**

1-888-225-7579 • [www.eacpds.com](http://www.eacpds.com) • Twitter @eacpds • YouTube.com/eacpds  
Training • Engineering & Design • Assessments • Software • Implementation

PTC<sup>®</sup> University • Learn  
**CREO<sup>™</sup>** • Design  
**Mathcad<sup>®</sup>** • Capture  
**Windchill<sup>®</sup>** • Collaborate



the **CadCARD** SLIDE CHART

ADDA Member Discounts 10%

<b>US Version CadCARD</b>	<b>\$18.90</b>
<b>ISO Metric CadCARD</b>	<b>\$18.90</b>
<b>ANSI/Arch Metric CadCARD</b>	<b>\$18.90</b>
<b>Wallet-Size CadCARD JR</b>	<b>\$ 7.20</b>
<b>All Four – One of Each</b>	<b>\$56.70</b>

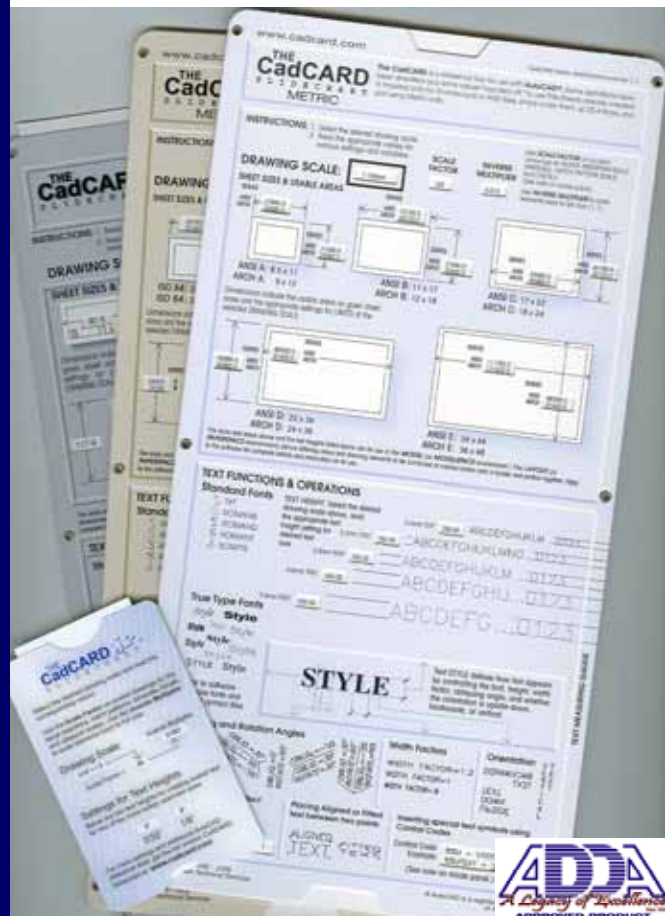

The full-featured CadCARD Slide Charts (U.S. or Metric Versions) are reference tools for use with AutoCAD. Designers, architects, engineers, and drafters find them to be quick, easy to use aids in many of the day-to-day CAD tasks that would otherwise have them reaching for a calculator. Instructors use CadCARDS to assist in explaining many CAD concepts such as scale and its effect on drawing elements. CadCARD JR features a reversible insert for calculating drawing scales, scale factors, inverse multipliers, and text heights for commonly used sheet sizes in both engineering *and* architectural units. CadCARDS become instant reference tools for everyone from the new user to the seasoned pro.

CadCARD Slide Charts are compatible with all versions of AutoCAD and other software that functions with AutoCAD. In addition, many features are useful with other CAD software such as IntelliCAD, Microstation, Solidworks, Revit, Solid Edge, BIM, Inventor, TurboCAD, and Mechanical Desktop.

**Free Shipping**      **Secure Ordering**

10% Discounts On-Line for ADDA Members

[www.cadcard.com/id40.html](http://www.cadcard.com/id40.html)

**Autograph Technical Services**

# International Museum of Design Drafting

Technical Illustration - Graphic Arts  
 Engineering and Architectural Design

ADDA authorized the creation of the International Museum of Design Drafting on April 16, 2010 in Louisville Kentucky with the purpose of collecting, displaying and preserving the history of the Design, Drafting, Architectural, Engineering and Graphics Professions for future generations.

**If you would like to donate monetarily, journals, tools, books or any items related to the profession it would be greatly appreciated. Currently about 400 items are on display in our lobby. ADDA is seeking more items with plans to build a facility to house the items in the future.**

**Help us Preserve our past for the future.**

A Subsidiary of the American Design Drafting Association - a 501(c)3 Non-Profit Corporation and Charity for the education and preservation of the design profession and history.



## SkillsUSA National Conference Moving to Louisville in 2015

Leesburg, Va., January 16, 2008 – SkillsUSA, a national organization of career and technical education students, instructors and business partners announced today that it will move its National Leadership and Skills Conference to Louisville, Ky., for six years beginning in 2015. The organization has grown into one of the largest student groups in the country. Its annual conference and SkillsUSA Championships has been held in Kansas City since 1994. Since then, registration has grown from 6,458 to more than 8,841. It is estimated over 14,000 people attended the conference in 2007 and as many as 18,000 will participate in 2015. The SkillsUSA national conference – then called the Vocational Industrial Clubs of America (VICA) – was held in Louisville from 1982 – 1984 and from 1991 – 1993.

“Our national conference and SkillsUSA Championships is the nation’s biggest and best showcase for career and technical education students and the skilled work force it prepares. We have an obligation to our members and sponsors to keep it growing,” said Tim Lawrence, executive director of SkillsUSA. “We look forward to being back in Louisville. As we plan for our continued growth, we know we will need larger convention facilities and over 6,000 hotel rooms nearby. Louisville meets those needs. And, the support of local education, business and industry is very important so we look forward to renewing old friendships and making some new ones,” Lawrence said. “SkillsUSA will use the next several years to begin transitioning to the Kentucky International Convention Center in Louisville.”

“Louisville won a competitive bid process, which attracted five other cities along the way all vying to become the next home to the SkillsUSA Championships,” said Shelly Coates, associate director for conference management services. “We have made this agreement seven years out to be sure the dates and space are there for SkillsUSA when we need them.”

More than 14,500 people—including students, teachers and business partners—are expected to participate in the weeklong event in 2008 and projected registration in 2015 is over 12,000. Participation could exceed 18,000. The SkillsUSA Championships currently occupies a space equivalent to 18 acres and could expand to 22.4 acres when the conference arrives in Louisville in 2015.

SkillsUSA is a partnership of students, teachers and industry working together to ensure America has a skilled work force. The organization serves more than 285,000 students and instructors annually, with 15,000 school chapters in 54 state and territorial associations. More than 15,600 instructors and administrators are professional members of SkillsUSA.

For more information about SkillsUSA, visit [www.SkillsUSA.org](http://www.SkillsUSA.org).

## New Membership Levels

ADDA has authorized two new professional membership levels for your convenience, described below.

**Select Professional Membership**—This membership is good for three years from the date of issue. Cost of the membership is \$210.00 which equates to only \$70.00 per year.

**Elite Professional Membership**—This membership is good for five years from the date of issue. Cost of the membership is \$325.00 which equates to only \$65.00 per year.

These membership levels are ideal to run in conjunction with professional certifications expirations, or for individual or companies wishing to take advantage of budgetary constraints.

The new Membership Renewal reflects these two new classifications and processes.

## Curriculum Certification Renewal Process now a little easier

The ADDA Board of Directors have authorized important changes in the Curriculum Certification Renewal Process.

All secondary curriculum certification packages will now be used for an initial period of three years. The annual renewal still applies with only the renewal application to complete and a program update form.

The post secondary renewal process is similar, except the initial period for these programs will be five years.

It should take less than 1 hour to complete the entire renewal package process for either program.

ADDA is conscientious of the many forms and regulations required for instruction and that each of these processes takes time away from the classrooms, students and lab times necessary to properly train the future drafter and designers.

The new information is now available for download from the website [www.adda.org](http://www.adda.org) or you may contact Pennie King at the office by calling 731-627-0802



## Graduate Lapel Pins

ADD<sup>A</sup> has authorized the creation of a new product for Certified Curriculum Program Graduates. These pins are 1" in diameter, with Turquoise and

Black Cloisonné filled with a bottom rocker indicating a Certified Program Graduate. These pins are available for \$5.00 each, or \$3.50 each if you order 2 or more. Price includes all shipping and handling. Pin orders must be made by the instructor and are shipped directly to the instructor of the program. No sales will be made to individuals.

## Graduate Certificates

As a reminder, Graduates from ADD<sup>A</sup> Certified Programs are entitled to Graduate Certificates indicating their completion from an ADD<sup>A</sup> Approved Program. These Certificates are not Certified Drafter Certificates. This only indicates ADD<sup>A</sup> has approved the material content of the schools curriculum.

Continued from page 4-Whitus

### AWARDS & RECOGNITION

The winning entries in each division are indicated by the following awards.

- BOARD OF GOVERNORS AWARD OF EXCELLENCE
- BOARD OF DIRECTORS AWARD
- PRESIDENTIAL AWARD

A recognition certificate is awarded to each of the three places in each Division. A minimum score of 70 is required to place. The Board of Governors winners also receive a \$100.00 cash prize and a voucher for the conference fees worth over \$600.00. The winners are also invited to accept their award during the awards ceremony during the annual conference.



**2013 Technical & Educational Conference**  
 April 09 - 12, 2013  
 Holiday Inn - Country Club Plaza  
 Kansas City Missouri

## ADD<sup>A</sup> Signature Products

Products Listed - Include cost of delivery  
 Please allow 2-3 weeks delivery time.  
 Express Delivery Available at additional cost.



Authentic Miniature Louisville Slugger Baseball Bat  
 ADD<sup>A</sup> Signature Cap Hidden Buckle Adjustable Strap  
**\$15.00 each**

ADD<sup>A</sup> Signature Shirts by Blue Generation  
 100% Cotton Twill - LS or SS - Men's and Women's  
 Over 20 Colors Available Men's Tall Available in Most Sizes  
 Visit: <http://www.bluegeneration.com/> search 8213 for colors / sizes



One Price - Any Size  
**\$33.00** Delivered

## GET INVOLVED with ADD<sup>A</sup>

Your Membership or Certification  
 should be more than a CARD

- Start a Professional Council
- Be a Contest Judge
- Promote Design Drafting Week
- Work with a local Chapter



### ADD<sup>A</sup> supports SkillsUSA Annually

- Provides the National SkillsUSA Drafting Examination
- Provides the National Drafting Contest Judges
- Award ADD<sup>A</sup> Membership to the SkillsUSA Winners
- ADD<sup>A</sup> Directors are Contest Program Chairs for the Architectural & Mechanical Competitions
- Assist in many State Competitions

## Do you know the difference between a counterbore and a spotface?

Dennis Schwartz

The ASME Y14.5-2009 Dimensioning and Tolerancing standard has added a specific symbol for identifying a spotface (see figure 1). To identify a counterbore, the counterbore symbol is used (see figure 2). Prior to the release of the 2009 standard, the counterbore symbol was used to identify both a counterbore and a spotface. There is a distinct difference between a counterbore and a spotface. The diameter of a counterbore is the actual diameter of the feature and is dimensioned as such (see figure 3).

SF

Figure 1 Spotface symbol  
 As shown on Drawing

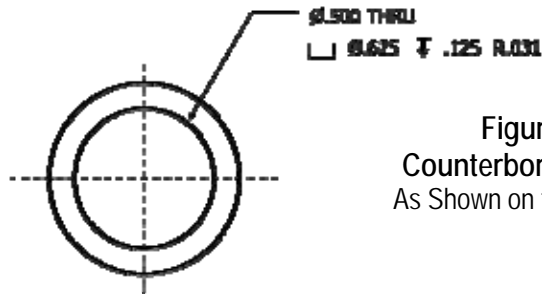

Figure 2  
 Counterbore Symbol  
 As Shown on the Drawing

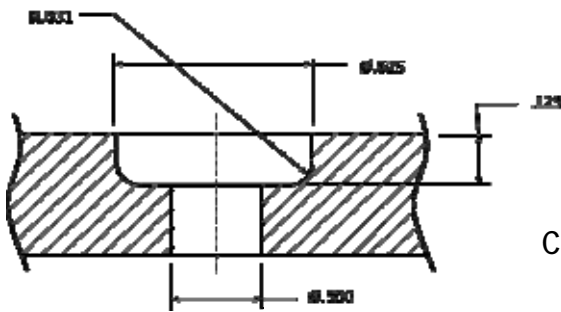

Figure 3  
 Counterbore Designation

The diameter of a spotface is the actual diameter of the spotfaced surface and is dimensioned as such (see figure 4). In most cases a spotface does not have a depth dimension because it is usually just deep enough to clean up the surface to the specified diameter. ASME Y14.5-2009 now allows the fillet radius to be specified in the counterbore or spotface callout (see figures 3 and 4). By using the appropriate designations for counterbores and spotfaces, there should be no confusion as to the requirement.

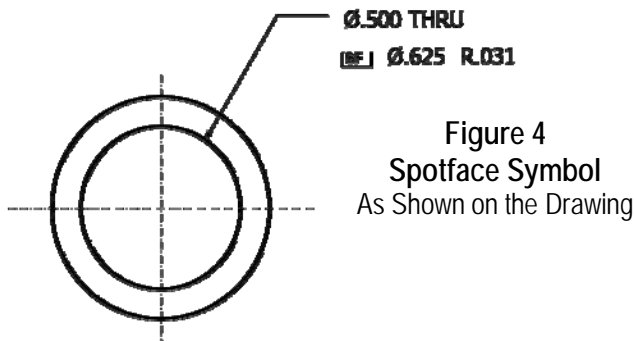

Figure 4  
 Spotface Symbol  
 As Shown on the Drawing

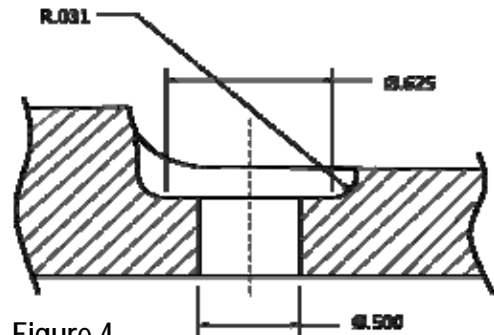

Figure 4  
 Spotface Designation



ADDA will be making a bold and interesting change of pace this year. We have chosen Kansas City Missouri as our Conference Site for the next 3 years, starting in 2013. We will be hosted by the Holiday Inn Plaza Hotel, located only one block from the historic Kansas City Country Club Plaza. After a long day of educational and training seminars you can relax in one of the dozens of eateries, have a Coldstone's Ice Cream or visit some of the unique shops and stores located here. It is a pleasant and level stroll throughout the Plaza.

Don't worry about walking. If you don't feel up to the scenic and majestic walk to the plaza. Holiday Inn will shuttle you there and back at no charge. They will also carry you to some of the other sites around Kansas City at no charge.

## Learn with us in KANSAS CITY

During the 4 days of the 54th Annual Conference we have lined up some of the most innovative speakers related to the Design Drafting and Graphics Profession. Don't plan on just listening. These are all workshops where you will take back time saving procedures and ideas to increase production.

### **GD&T Fundamentals**

**ArchiCAD Workshop**  
**Pro-E CREO**  
**MathCAD**  
**Introduction to Stacks**  
**Sustainable Design**  
**Chief Architect Workshop**  
**Workplace Ethics**

### **GD&T Applications**

**Professional Development**  
**ASME Standards**  
**Designing for DOD**  
**IronCAD**  
**Green Building**  
**AutoCAD Workshop**  
**Skills USA**

### **Building Information & Modeling**

**Process Piping Workshop**  
**Solidworks Workshop**  
**3D Fundamentals**  
**BIM Applications & Implementation**  
**LEED**  
**AutoCAD 2014**  
**Industry Roundtable**

## Exhibit with us in KANSAS CITY

We will have some of the leaders in the industry exhibiting their products and services which can impact the future of design and graphics. You will have the opportunity to speak one-on-one to the management of these organization and discuss implementation of and use of their products.

### **Bauer Ethics**

**Chief Architect**  
**Solidworks**  
**Global Computer**  
**MathCAD**  
**PTC-Creo**

### **BizSupplies**

**Delmar Cengage**  
**Drafting Steals**  
**Hearlihy**  
**McGraw Hill**  
**Goodheart Wilcox**

### **CAD Academy**

**Design Data**  
**Bentley**  
**IronCAD**  
**Pearson**  
**CADcard**

### **SDC**

**TSI**  
**EAC**  
**ASME**  
**ASTS**

To obtain additional information visit [www.adda.org](http://www.adda.org)